

Description

The TZK Series is designed for machines/work cells where access to a hazardous work area must be controlled until safe conditions exist. Their solenoid-latching feature permits locking a machine guard until dangerous conditions, which may exist immediately after removal of power, have abated. Solenoid-latching may be controlled by a time delay, motion detector, position sensor or other suitable component.

The unit's contact arrangement permits the prevention of a machine restart until the guard is closed and in the locked position.

Each unit is supplied with a 1/2" NPT conduit adapter.

Operation

The TZK Series electromechanical safety interlock switch consists of a rugged switch with a solenoid-latching mechanism and a geometrically-unique actuating key. The switch actuating key is typically mounted to a movable machine guard.

When the guard is closed, the actuating key is held in position by the solenoid-latching mechanism. The guard may only be opened by energizing or de-energizing (depending upon model) the solenoid-latching mechanism.

Upon opening of the guard, the switch's "positive-break" NC contacts are forced to open through a direct (non-resilient) mechanical linkage with the actuating key. The NO contacts close upon key removal.

Features & Benefits

- **Solenoid-locking design** ... controls access to hazardous areas until safe conditions exist.
- **Highly tamper-resistant** ... difficult to defeat with simple tools, tape, bent wires, etc. Reduces liability exposure.
- **"Positive-break" NC contacts** ... ensure circuit interruption upon key removal.
- **Watertight design** ... meets IP67 environmental sealing requirements.
- **Positive locking** ... integral mechanical interlock prevents solenoid latching until actuating key is fully inserted.
- **High-strength steel actuator key** ... tolerates mechanical abuse without damage.
- **Rugged, corrosion-resistant housing** ... tolerates the most hostile environments.
- **Available in "solenoid-locking" and "solenoid-unlocking" models** ... for application versatility.
- **Optional "floating" actuator key** ... tolerates up to 5mm of guard misalignment without damage.
- **Meets rigid safety agency standards** ... IEC, BG (UL and CSA pending)
- **Rotatable actuating head** ... four user-selectable 90° positions for installation flexibility.
- **Funnel entry** ... forgiving of minor guard misalignment.
- **Optional spring-loaded actuator keys** ... tolerates axial misalignment of guard.
- **Built-in key entry dust cover** ... prevents ingress of dirt and dust when key is removed.

Typical Applications



The TZK Series is intended for use as a safety interlock switch on movable machine guards which must not be opened until dangerous conditions, that may exist after the removal of power, have abated. Such conditions are flywheel overrun, spindle momentum, unstable rest positions, etc. Typical applications are textile machines, stamping presses, articulating robot arms, mixing machines, heavy working equipment, printing presses and packaging machinery.

SERIES TZK AVAILABLE MODELS AND ACCESSORIES

AVAILABLE STANDARD MODELS

(Includes 1/2" NPT Adapter. Order desired actuator key separately)

Part Number*	Contacts (Guard Closed)	Description
TZKF/CS*	1 NO & 2 NC	Actuating key locked by spring and unlocked by energizing solenoid
TZKM/C*	1 NO & 2 NC	Actuating key locked by energizing solenoid and unlocked by de-energizing solenoid (See Note 1 below)

*Please specify solenoid operating voltage via addition of one of the following suffix codes:

Voltage	Add Suffix
24VDC	No Suffix
115VAC	-115VAC
230VAC	-230VAC

Example: TZKF/CS-115VAC

Note 1: Use of this model permits the guard to be opened in the event of a power failure. Generally accepted safety standards/practices suggest this model only be used after conducting a thorough risk evaluation in the context of the application.

ACTUATOR KEYS & ACCESSORIES

Part Number	Description
TZK/CO	Standard straight actuating key
TZK/CW	Standard right-angle actuating key
TZK/COF	Spring-loaded actuator key tolerates axial movement of +7.5°/-15° or -7.5°/+15° depending upon mounting orientation
TZK/CORF/7.5	Pre-tensioned, spring-loaded actuator key tolerates axial movement of +7.5° or -7.5° depending upon mounting orientation
TZK/CORF/15	Pre-tensioned, spring-loaded actuator key tolerates axial movement of +15° or -15° depending upon mounting orientation
TZK/APL	Mounting adapter plate facilitates easy alignment between actuating key and interlock
TZ-69	Standard straight auxiliary release key
TZ-75	Right-angle auxiliary release key
AZS2305	Fail-to-Safe Timer (Please see page 80)
FWS1205B	Fail-to-Safe Standstill Monitor (Page 80)

2

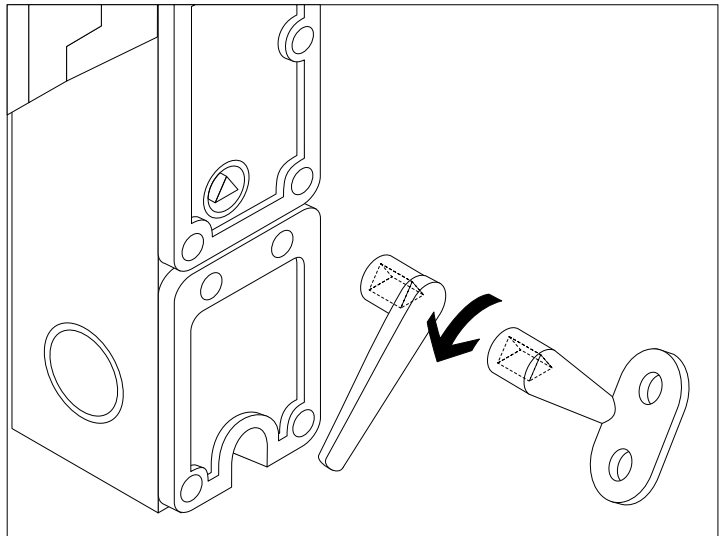

Auxiliary release keys
(for locking via spring models)

SERIES TZK TECHNICAL DATA

MECHANICAL SPECIFICATIONS

Housing	Glass-fibre reinforced, self-extinguishing thermoplastic
Actuator Key	Galvanized steel
Degree of Protection	IP67
Travel for Positive-Break	2.3mm
Key Insertion Force	10 N (2.2 pounds)
Key Holding Force (without solenoid-latching)	20 N (4.4 pounds)
Solenoid Locking Force	2,000N (440 pounds)
Operating Temperature	+32°F to +122°F (0°C to +50°C)
Mechanical Life	2 x 10 ⁶ Operations (minimum)
Mounting Orientation	Any position
Solenoid Override	Manual release from front surface
Slack Resistance	30g / 11ms
Vibration Resistance	20g / 10-55Hz
Switching Frequency	120 cycles/hour (maximum)
Conformity to Standards	IEC 947 EN 60947 DIN VDE 0660 EN 1088 UL & CSA
Minimum Closing Radius	6.9" (175mm) for CO and CORF actuating key 9.8" (250mm) for CW actuating key 5.9" (150mm) for COF actuating key

ELECTRICAL SPECIFICATIONS

Contacts	Silver-plated, gold
Contact Configuration	Double-pole, double-break, electrically-separated contact bridges
Contact Rating	8A/115VAC, 15A/250VAC (AC 15) 13A/24VDC (DC13)
Switching Action	Slow-action, positive-break NC contacts
Short Circuit Protection	10A
Rated Insulation Voltage	250VAC
Rated Impulse Withstand Voltage	2.5 KV
Type Terminals	Screw terminals with self-lifting cable clamps for up to 13AWG flexible stranded wire (1.5mm ²)
Available Solenoid Voltages	24VDC 115VAC/50-60 Hz 230VAC/50-60 Hz
Solenoid Power Consumption	10W (maximum)
Solenoid Duty Cycle	100%

SWITCHING DIAGRAMS & CONTACT SCHEMATICS

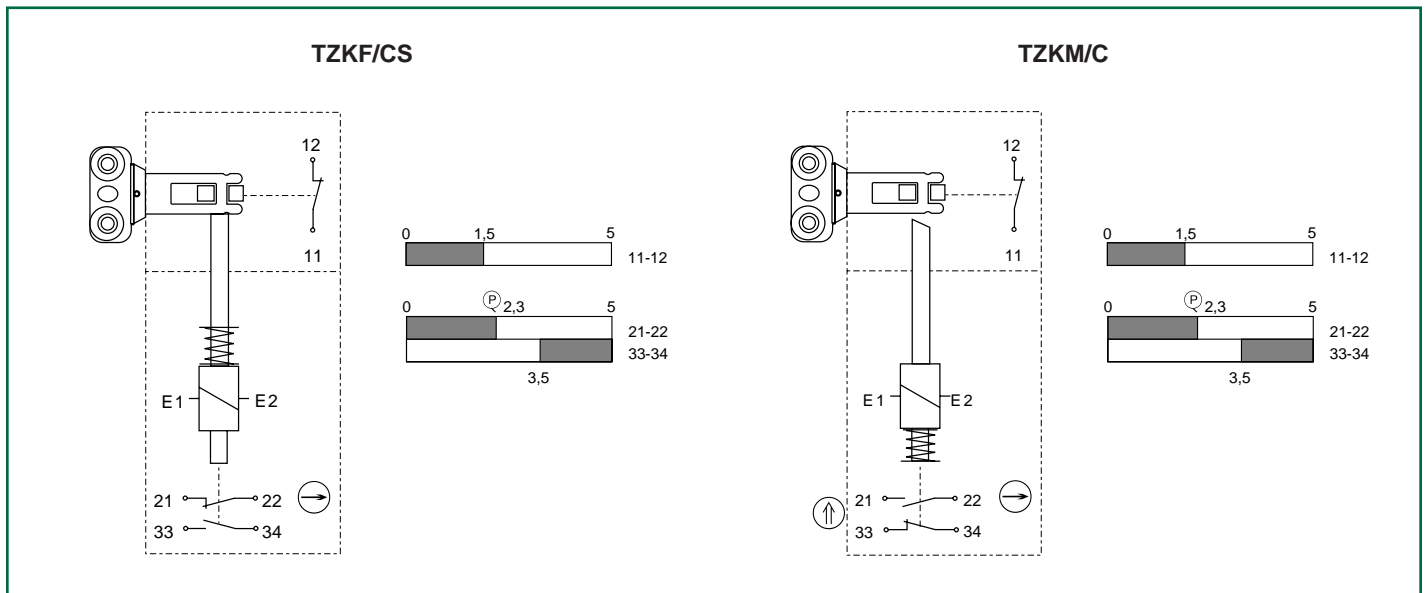

SERIES TZK TECHNICAL DATA

DIMENSIONS (Basic Switch & Optional Mounting Adapter Plate)

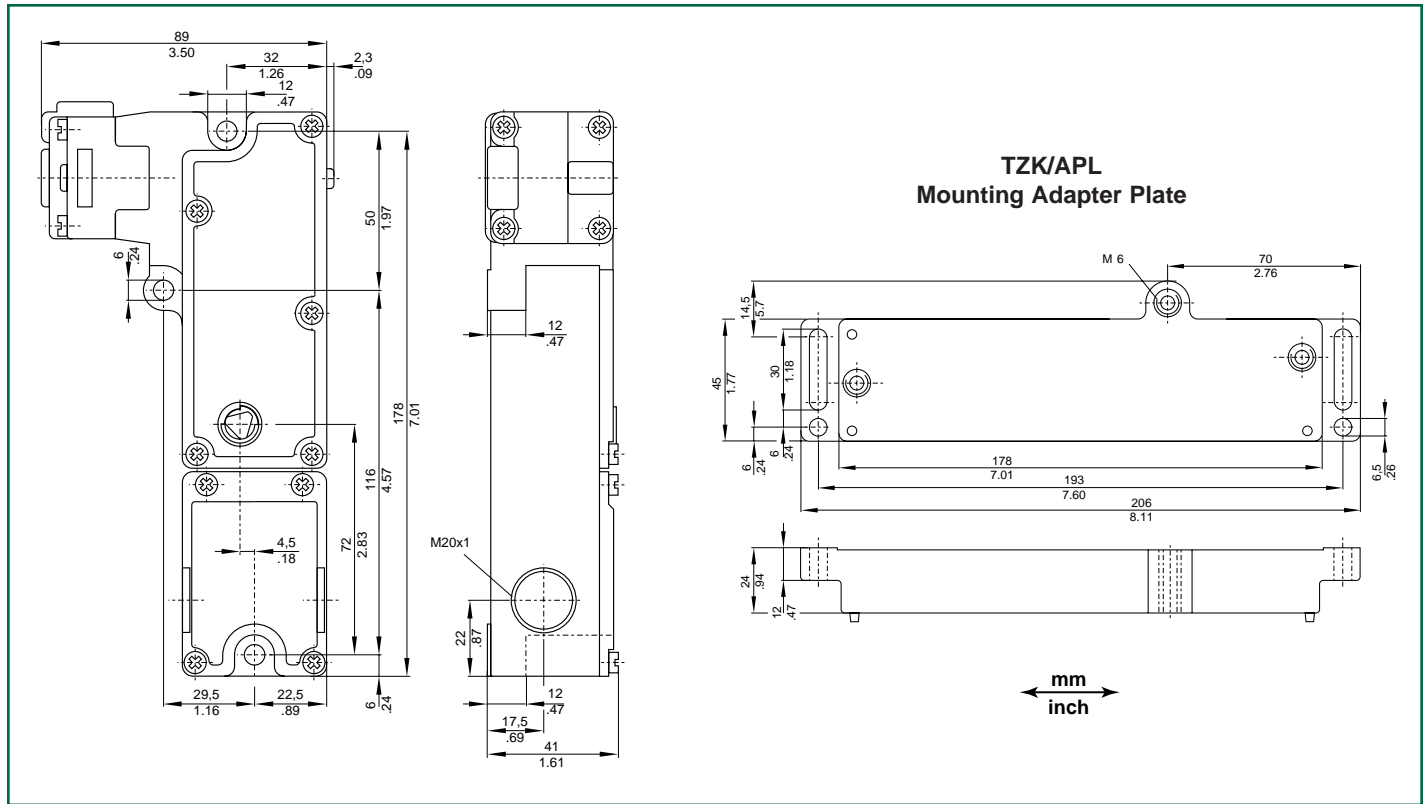

ACTUATOR KEY DIMENSIONS

