

Description

The TZF/TZM Series is designed for machines/work cells where access to a hazardous work area must be controlled until safe conditions exist. Their solenoid-latching feature permits locking a machine guard until dangerous conditions, which may exist immediately after removal of power, have abated. Solenoid-latching may be controlled by a time delay, motion detector, position sensor or other suitable component.

The unit features independent actuator key (guard) position and solenoid-latching monitoring contacts. These permit the prevention of machine restart until the guard is closed **and** the solenoid-latching pin is in the locked position.

The TZF/TZM Series consists of an electromechanical safety interlock switch with “positive-break” contacts and a locking actuator key. In addition, the TZFS model features an auxiliary manual unlocking device ... the latter provided to aid in installation and for use in the event of a power failure (when using the “unlocking by solenoid” model).

Operation

The TZF/TZM Series of electromechanical safety interlock switch assembly consists of a rugged switch, a solenoid-operated latching mechanism, and a geometrically-unique actuator key. The switch actuating key is typically mounted to a movable machine guard.

When the guard is closed, the actuating key is held in position by the latching mechanism. The guard may only be opened by energizing or de-energizing (depending upon model) the latching mechanism.

Upon opening of the guard, the switch’s “positive-break” NC contacts are forced to open through a direct (non-resilient) mechanical linkage with the actuating key. The NO contacts close upon key removal.

The solenoid-latching mechanism circuit features a NO and a NC contact which permit monitoring its status. This NC contact is wired in series with the NC contact in the safety switch circuit. Thus the machine is prevented from starting until the actuating key is inserted (guard is closed) *and* the solenoid has locked it in the closed position.

Features & Benefits

- **Solenoid-locking & spring-locking designs** ... controls access to hazardous areas until safe conditions exist.
- **Highly tamper-resistant** ... difficult to defeat with simple tools, tape, bent wires, etc. Reduces liability exposure.
- **“Positive-break” NC contacts** ... assure circuit interruption upon actuator key removal.
- **Conditional “safe” outputs** ... actuating key must be fully inserted and solenoid must be actuated to lock key before “closed” safety signal is provided.
- **Watertight design** ... meets IP67 environmental requirements.
- **High-strength, galvanized-steel actuator key** ... tolerates mechanical abuse without damage.
- **Rugged, corrosion-resistant housing** ... tolerates hostile environments.
- **Three optional key entry locations** ... rotatable actuator head provides installation versatility.
- **Independent actuator key position and locking pin position monitoring contacts** ... provide a higher degree of safety.
- **Padlockable key** ... for added security during equipment maintenance.
- **Meets rigid safety agency standards** ... BG, UL, CSA.
- **Wide selection of actuating keys** ... to meet diverse application requirements.
- **Special types for food industry** ... please consult factory.

Typical Applications



The TZF/TZM Series is intended for use as a safety interlock switch on movable machine guards which must not be opened until dangerous conditions, which may exist after the removal of power, have abated. Such conditions are flywheel overrun, spindle momentum, unstable rest positions, etc. Typical applications are textile machines, stamping presses, articulating robot arms, mixing machines, metal working equipment, printing presses and packaging machinery.

SERIES TZF/TZM AVAILABLE MODELS AND ACCESSORIES

AVAILABLE STANDARD MODELS

(Includes 1/2" NPT Plastic Conduit Adapter and TZ/CO Standard Actuator key)

Part Number	Contacts	Description
TZFCS/96-*	2NC & 1 NO (NC contacts in series)	Actuating key locked by spring and unlocked by energizing solenoid with right-side key entry. (Field-rotatable for entry from front or rear).
TZMC/96-*	2NC & 1 NO (NC contacts in series)	Actuating key locked by energizing solenoid and unlocked by spring with right-side key entry. (Field-rotatable for entry from front or rear). (See Note 1 below)

*Please specify solenoid operating voltage via addition of one of the following suffix codes:

Voltage	Add Suffix
24VDC	No Suffix
115VAC	-115
230VAC	-230

Example: TZMC/96-115

Note 1: Use of this model permits the guard to be opened in the event of a power failure. Generally accepted safety standards/practices suggest this model only be used after conducting a thorough risk evaluation in the context of the application.

OPTIONAL ACTUATOR KEYS & ACCESSORIES

Part Number	Description
TZ/CO	Standard straight actuator key (13" minimum closing radius)
TZ/CW	Right-angled straight actuator key (11.8" minimum closing radius)
TZ/COR	Radial entry actuator key (11.8" minimum closing radius)
TZ/CK	Short straight actuator key (6.3" minimum closing radius)
TZ/CWR	Right-angled bent actuator key (11.8" minimum closing radius)
TZ/COF/HIS.1	Pivoting straight actuator key (rear-mounted) (13.8" minimum closing radius)
TZ/COF/HIS.2	Pivoting straight actuator key (top-mounted) (13.8" minimum closing radius)
TZ/CORF/HIS.1	Pivoting straight actuator key (rear-mounted) (7.1" minimum closing radius)
TZ/CORF/HIS.2	Pivoting straight actuator key (top-mounted) (5.9" minimum closing radius)
TZ-65	Straight safety interlock auxiliary release key (for TZFCS/96 models only)
TZ-75	Right-angled safety interlock auxiliary release key (for TZFCS/96 models only)
AZS2305	Fail-to-Safe Timer (Please see page 80)
FWS1205B	Fail-to-Safe Standstill Monitor (Page 80)

SERIES TZF/TZM TECHNICAL DATA

MECHANICAL SPECIFICATIONS

Housing	Glass-fibre reinforced self-extinguishing thermoplastic
Actuator Key	Galvanized steel (defeat-resistant design)
Degree of Protection	IP67
Unlocked Holding Force	20N (4.8 pounds)
Travel for Positive-Break	14.5 mm
Force to Reach Positive-Break	20N (Approx. 4.8 pounds)
Closing Force	Approx. 10 N (2.4 pounds)
Operating Temperature	-13°F to +104°F
Mechanical Life	2 million operations (minimum)
Shock Resistance	30g / 11ms
Vibration Resistance	20g / 10...55Hz
Conformity to Standards	IEC 947-5-1 EN 60947-5-1 DIN VDE 0660-100 BG-GS-ET-15 UL CSA
Solenoid Locking Force	1,700N (380 pounds)
Minimum Closing Radius	Dependent upon actuator key used. Please see actuator key selection chart.

ELECTRICAL SPECIFICATIONS

Contacts	Fine silver
Contact Configuration	Double-pole, double-break with electrically separated contact bridges
Contact Gap	Guard monitoring: 2 × 3.5 mm Solenoid monitoring: 2 × 3 mm
Contact Rating	8A (250VAC)
Switching Action	Slow-action, positive-break NC contacts
Short Circuit Protection	10A (slow-blow)
Rated Insulation Voltage	250VAC
Rated Impulse Withstand Voltage	4kV
Type Terminals	Screw terminals with self-lifting clamps for up to 13 AWG solid wire (2.5mm ²) or 13 AWG stranded (1.5mm ²) wire
Available Solenoid Voltages	24VDC 115VAC 230VAC
Solenoid Power Consumption	8.8W (maximum)
Solenoid Duty Cycle	100%

WIRING DIAGRAM*

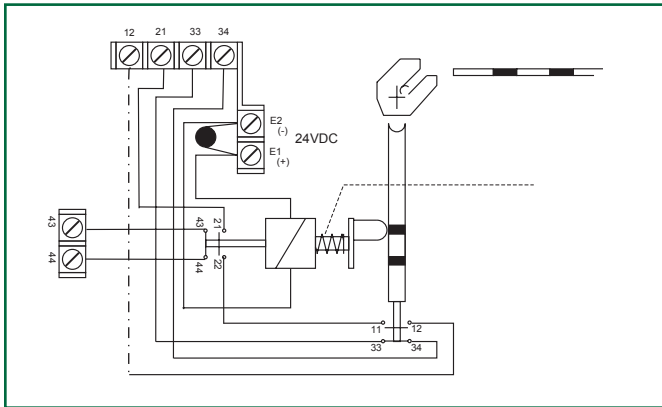

* Actuating key not inserted and solenoid unlocked.

DIMENSIONS

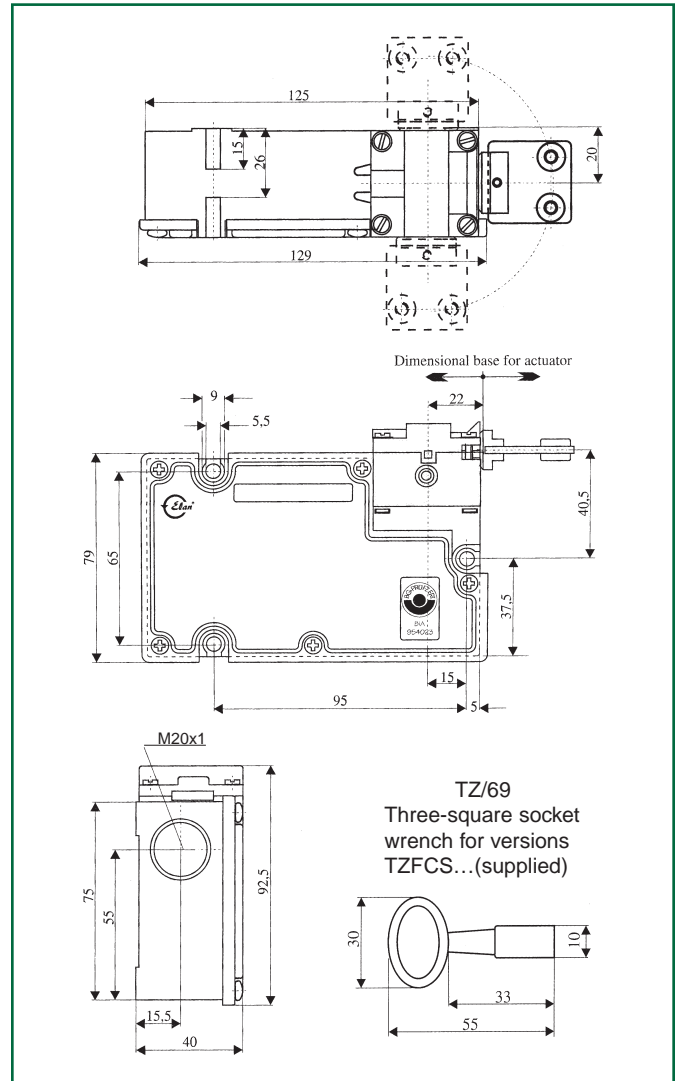

SERIES TZF/TZM ACTUATOR KEY SPECIFICATIONS

ACTUATOR KEYS

