



### Features & Benefits

- **Solenoid-locking design** ... controls access to hazardous areas until safe conditions exist.
- **Highly tamper-resistant** ... difficult to defeat with simple tools, tape, bent wires, etc. Reduces liability exposure.
- **“Positive-break” NC contacts** ... assure circuit interruption upon actuator key removal.
- **Conditional “safe” outputs** ... actuating key must be fully inserted and solenoid must be actuated to lock key before “closed” safety signal is provided.
- **Watertight design** ... meets IP67 environmental requirements.
- **High-strength, stainless-steel actuator key** ... tolerates mechanical abuse without damage.
- **Rugged, corrosion-resistant housing** ... tolerates hostile environments.
- **Four optional key entry locations** ... provide installation flexibility.
- **Independent actuator key position and locking pin position monitoring contacts** ... provide a higher degree of safety.
- **Available in “solenoid-locking” and “solenoid-unlocking” models** ... for application versatility.
- **Meets rigid safety agency standards** ... IEC, BG, UL and CSA.
- **Wide selection of accessories** ... to meet diverse application requirements.

### Description

The AZM161 Series is designed for machines/work cells where access to a hazardous work area must be controlled until safe conditions exist. Their solenoid-latching feature permits locking a machine guard until dangerous conditions, which may exist immediately after removal of power, have abated. Solenoid-latching may be controlled by a time delay, motion detector, position sensor or other suitable component.

The unit features independent actuator key (guard) position and solenoid-latching monitoring contacts. There is a mechanical linkage preventing the solenoid position contacts from changing unless the key is inserted (guard closed).

The AZM161 consists of an electromechanical safety interlock switch section with “positive-break” NC contacts and an actuator key. In addition, the solenoid mechanism features 1 NO and 2 NC solenoid-latching monitoring contacts, and an auxiliary manual unlocking device ... the latter provided to aid in installation and for use in the event of a power failure (when using the “unlocking by solenoid” model).

### Operation

The AZM161 electromechanical safety interlock switch assembly consists of a rugged switch-solenoid-latching mechanism and a geometrically-unique locking actuator key. The switch actuating key is typically mounted to a movable machine guard.

When the guard is closed, the actuating key is held in position by the solenoid-latching mechanism. The guard may only be opened by energizing or de-energizing (depending upon model) the solenoid-latching mechanism.

Upon opening of the guard, the switch’s “positive-break” NC contacts are forced to open through a direct (non-resilient) mechanical linkage with the actuating key. The NO contacts close upon key removal.

The machine is prevented from starting until the actuating key is inserted (guard is closed) *and* the solenoid has locked it in the closed position.

### Typical Applications



The AZM161 is intended for use as a safety interlock switch on movable machine guards which must not be opened until dangerous conditions, which may exist after the removal of power, have abated. Such conditions are flywheel overrun, spindle momentum, unstable rest positions, etc. Typical applications are textile machines, stamping presses, articulating robot arms, mixing machines, metal working equipment, printing presses and packaging machinery.

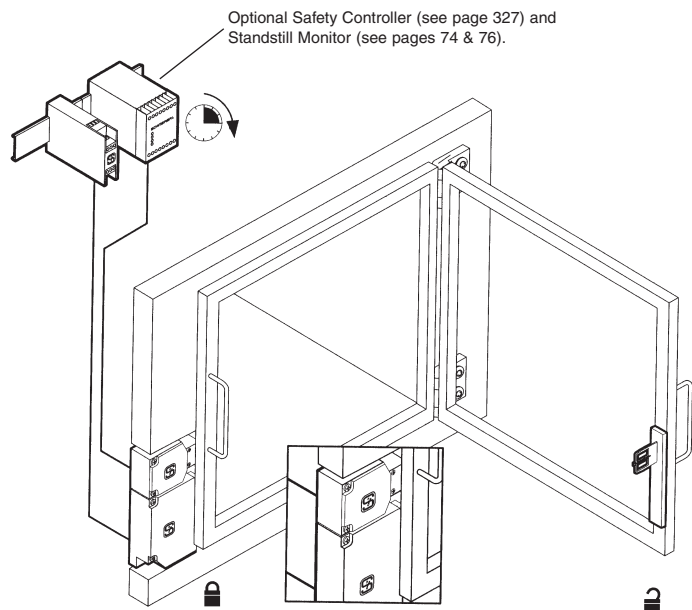

# AZM161 AVAILABLE MODELS AND ACCESSORIES

## AVAILABLE STANDARD MODELS (Includes 1/2" NPT Plastic Adapter. Actuator key sold separately)

Part Number	Contacts	Description
AZM161SK-12/12rk-	2NO & 4 NC	Actuating key locked by spring and unlocked by energizing solenoid.
AZM161SK-12/12rka-	2NO & 4 NC	Actuating key locked by energizing solenoid and unlocked by spring. (See Note 1 below)

Please specify solenoid operating voltage via addition of one of the following suffix codes:

<b>Voltage</b>	<b>Add Suffix</b>
24VAC/DC	-24VAC/DC
110/230VAC	-110/230VAC

Example: AZM161SK-12/12rk-24VAC/DC

Add suffix "T" after the "k" for Manual Emergency Release

**Note 1: Use of this model permits the guard to be opened in the event of a power failure. Generally accepted safety standards/practices suggest this model only be used after conducting a thorough risk evaluation in the context of the application.**

POSITIVE-BREAK® is a trademark of SCHMERSAL

## AVAILABLE KEYS & ACCESSORIES for AZM161 Keyed-Interlock Switches

Part Number	Description
AZM161-B1	Standard actuating key
AZM161-B1E	Standard actuating key with heavy-duty mounting bracket
AZM161-B6	Small radius actuating key
AZM161-B6-2177	Funnel entry adapter with elongated flexible-movement actuating key
AZM-Key	Solenoid-latch bypass key
M16-CG	Cord grip (cable gland)
M16-1/2"P	Plastic 1/2" NPT adapter
M16-1/2"M	Metal 1/2" NPT adapter
PL-M16-24V	24VAC/DC pilot light kit
PL-M16-120V	120VAC/DC pilot light kit
Add suffix -1637 to basic part number	Gold contacts
MS AZM 161-P	Adjustable mounting kit for parallel mounting
MS AZM 161-R/P	Adjustable mounting kit for parallel or perpendicular mounting
AZS2305	Fail-to-Safe Timer (Please see page 74)
FWS1205B	Fail-to-Safe Standstill Monitor (Page 76)

MS mounting kits require the use of -B6 keys

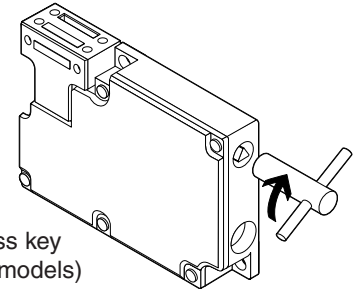

Solenoid-latch bypass key  
(for locking via spring models)

## MS AZM 161 ADJUSTABLE MOUNTING KIT (Eases installation and facilitates adjustments due to guard misalignment)

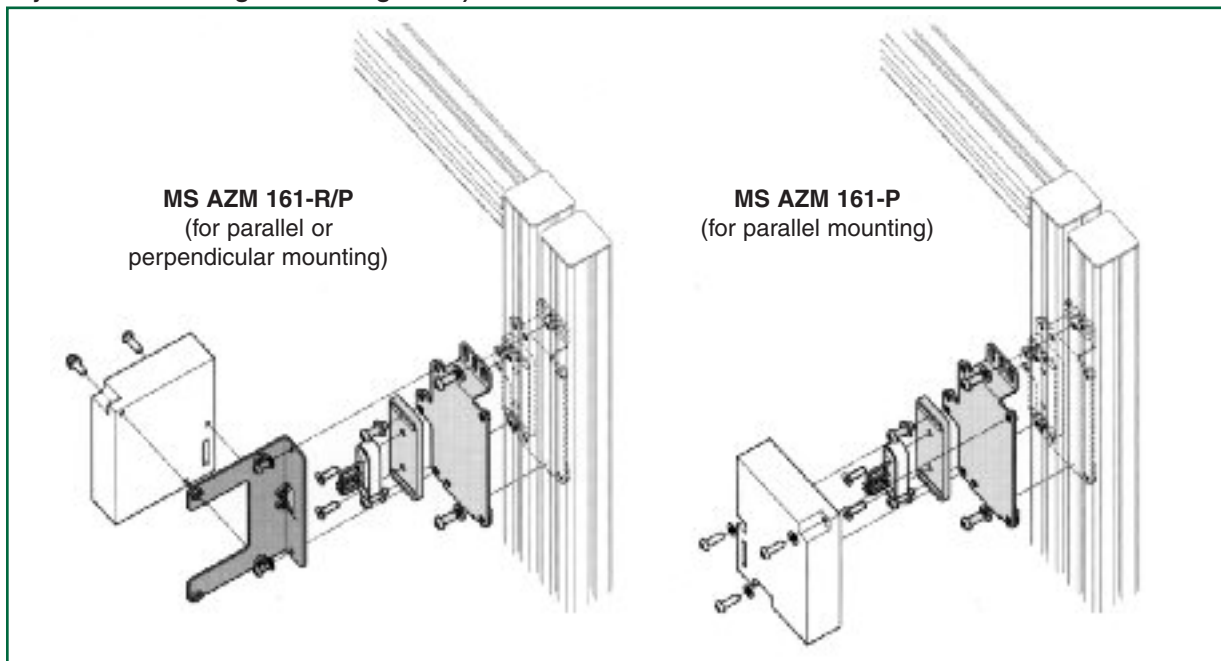

**MS AZM 161-R/P**  
(for parallel or perpendicular mounting)

**MS AZM 161-P**  
(for parallel mounting)

# AZM161 TECHNICAL DATA

## MECHANICAL SPECIFICATIONS

<b>Housing</b>	Glass-fibre reinforced self-extinguishing thermoplastic
<b>Actuator Key</b>	Stainless steel (defeat-resistant design)
<b>Degree of Protection</b>	IP67
<b>Unlocked Holding Force</b>	30N (7 pounds)
<b>Travel for Positive-Break</b>	8mm (0.315 inches)
<b>Force to Reach Positive-Break</b>	10N (Approx. 2.4 pounds)
<b>Closing Force</b>	Approx. 15 N (3.4 pounds)
<b>Operating Temperature</b>	-13°F to +104°F
<b>Mechanical Life</b>	1 million operations
<b>Conformity to Standards</b>	IEC 947-5-1 EN 60947-5-1 DIN VDE 0660-200 BG-GS-ET-15 UL CSA
<b>Solenoid Locking Force</b>	2,000N (440 pounds)
<b>Key Return Force</b>	0N
<b>Minimum Closing Radius</b>	5.9" (150mm) with B1 and B1E actuating key 3.7" (95mm) with B6 actuating key

## ELECTRICAL SPECIFICATIONS

<b>Contacts</b>	Fine silver
<b>Contact Configuration</b>	Double-pole, double-break with electrically separated contact bridges
<b>Contact Gap</b>	2 x 2 mm (minimum)
<b>Contact Rating</b>	4A (230VAC)
<b>Switching Action</b>	Slow-action, positive-break NC contacts
<b>Short Circuit Protection</b>	Fuse 6A (time-delay)
<b>Rated Insulation Voltage</b>	250VAC
<b>Rated Impulse Withstand Voltage</b>	6kV
<b>Type Terminals*</b>	Screw terminals with self-lifting clamps for up to 13 AWG flexible stranded wire (2.5mm <sup>2</sup> )
<b>Available Solenoid Supply Voltages (Vs)</b>	24VDC, 110VDC, 230VDC 24VAC/50Hz 115VAC/60Hz 230VAC/50Hz
<b>Solenoid Power Consumption</b>	10W (maximum)
<b>Solenoid Duty Cycle</b>	100%
<b>Solenoid Pull-in Voltage</b>	(0.85 to 1.1) Vs
<b>Solenoid Drop-out Voltage</b>	(0.2 to 0.75) Vs

\*Optional cage clamp terminations available.  
Please consult factory.

## SWITCHING DIAGRAMS & CONTACT SCHEMATICS (Solenoid-mechanism not energized)

AZM 161SK-12/12rk

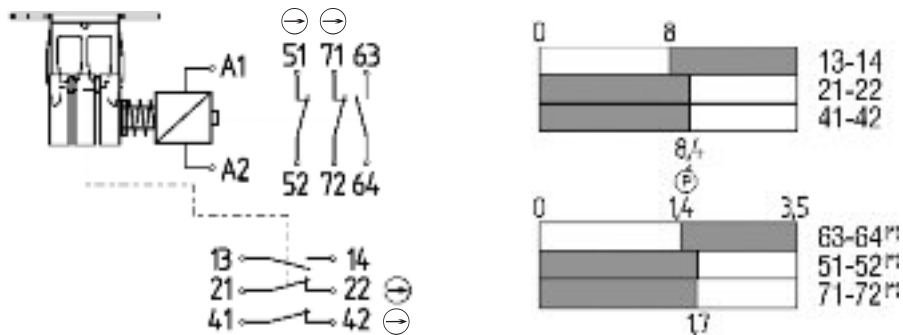

AZM 161SK-12/12rka

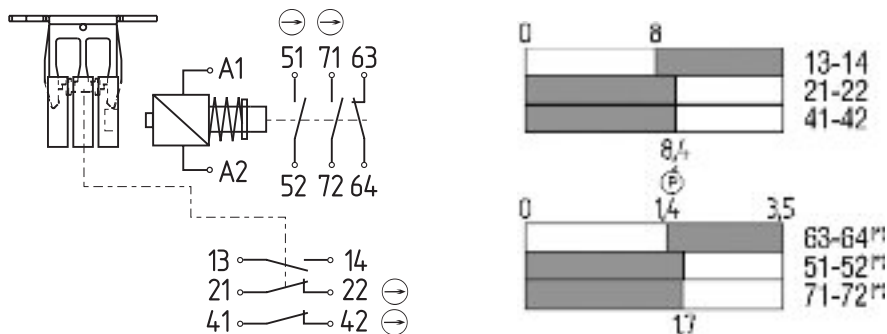

# AZM161 TECHNICAL DATA

## DIMENSIONS (Switch & Actuator Keys)

